



Cambridge International Examinations
Cambridge International General Certificate of Secondary Education

CANDIDATE
NAME

--

CENTRE
NUMBER

--	--	--	--	--

CANDIDATE
NUMBER

--	--	--	--



COMBINED SCIENCE

0653/33

Paper 3 (Extended)

May/June 2016

1 hour 15 minutes

Candidates answer on the Question Paper.

No Additional Materials are required.

READ THESE INSTRUCTIONS FIRST

Write your Centre number, candidate number and name on all the work you hand in.

Write in dark blue or black pen.

You may use an HB pencil for any diagrams or graphs.

Do not use staples, paper clips, glue or correction fluid.

DO NOT WRITE IN ANY BARCODES.

Answer **all** questions.

Electronic calculators may be used.

You may lose marks if you do not show your working or if you do not use appropriate units.

A copy of the Periodic Table is printed on page 20.

At the end of the examination, fasten all your work securely together.

The number of marks is given in brackets [] at the end of each question or part question.

This document consists of **20** printed pages.

1 Paper chromatography can be used to separate and identify a compound in a mixture of compounds. A compound consists of one or more elements that are chemically combined.

(a) (i) Define the term *mixture*.

.....

.....

.....

..... [2]

(ii) A student uses paper chromatography to find out which compounds a mixture **Y** contains. Fig. 1.1 shows the chromatogram of the student's results.

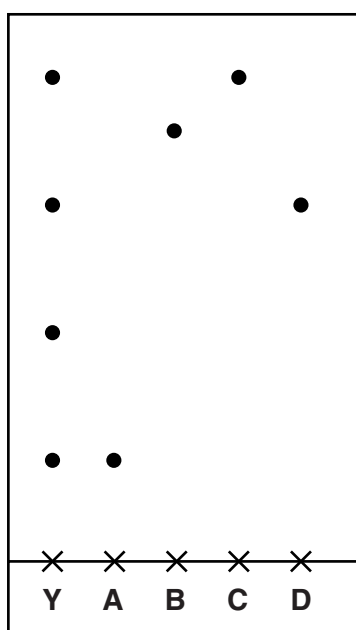

Fig. 1.1

Deduce which of the compounds **A**, **B**, **C** and **D** the mixture **Y** contains.

Explain your answer.

.....

.....

.....

..... [2]

- (b) Scientists use chromatography to detect the presence of the compound ethanol in blood.

Complete Fig. 1.2 to show the structure of one molecule of ethanol.



Fig. 1.2

[2]

- (c) (i) Ethanol is produced when ethene reacts with steam. No other product is made in this reaction.

Write the word equation for the reaction of ethene with steam to make ethanol.

..... [1]

- (ii) Draw a dot-and-cross diagram to show the bonding in ethene.

You only need to show the arrangement of the outer electrons.

[2]

- (iii) Ethane and ethene are both hydrocarbons.

Describe a chemical test to distinguish between ethane and ethene.

test

.....

result for ethane

.....

result for ethene

.....

[3]

2 Fig. 2.1 shows an electric circuit.

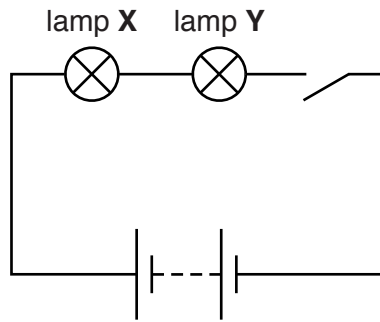

Fig. 2.1

- (a) The potential difference (p.d.) supplied by the battery is 12 V. The p.d. across lamp **X** is 2 V.
Calculate the p.d. across lamp **Y**.

potential difference = V [1]

- (b) The current through lamp **X** is 0.4 A.

- (i) Calculate the resistance of lamp **X**.

State the formula you use, show your working and state the unit of your answer.

formula

working

resistance = unit = [3]

- (ii) Calculate the power in the circuit when the current in the circuit is 0.4 A.
State the formula you use and show your working.

formula

working

power = W [2]

- (iii) Explain why the energy transferred in lamp X is less than the energy transferred in lamp Y.

.....

 [1]

- (c) Fig. 2.2 shows a different circuit.

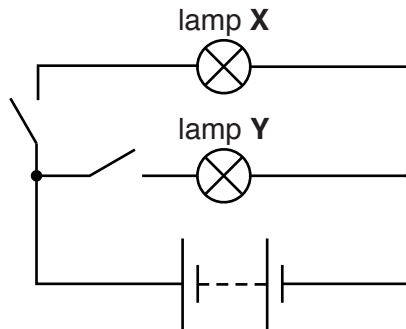

Fig. 2.2

Explain why lights in a house are connected as in the circuit in Fig. 2.2 and not as shown in the circuit in Fig. 2.1.

.....

 [2]

- 3 The apparatus in Fig. 3.1 is used to investigate the effect of light intensity on the rate of photosynthesis in the aquatic plant *Elodea*.

The intensity of light is varied by changing the distance of the plant from the lamp. The light intensity increases as the distance from the plant decreases.

The rate of photosynthesis is measured by counting the number of bubbles of oxygen produced by the plant per minute.

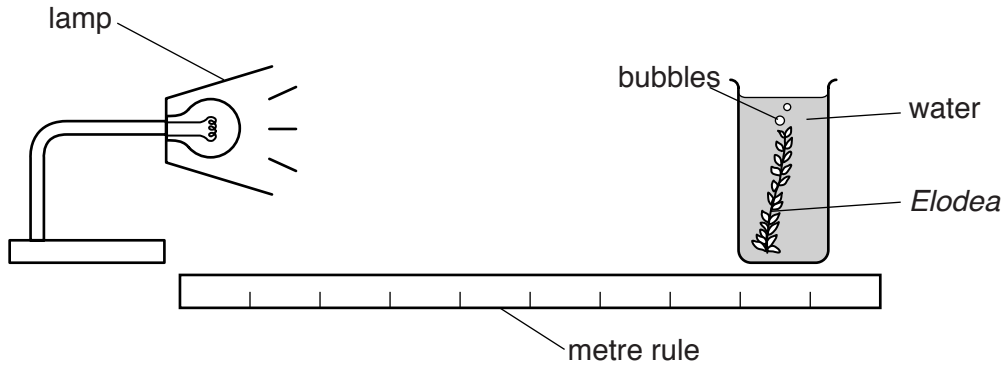

Fig. 3.1

The results are used to produce the graph shown in Fig. 3.2.

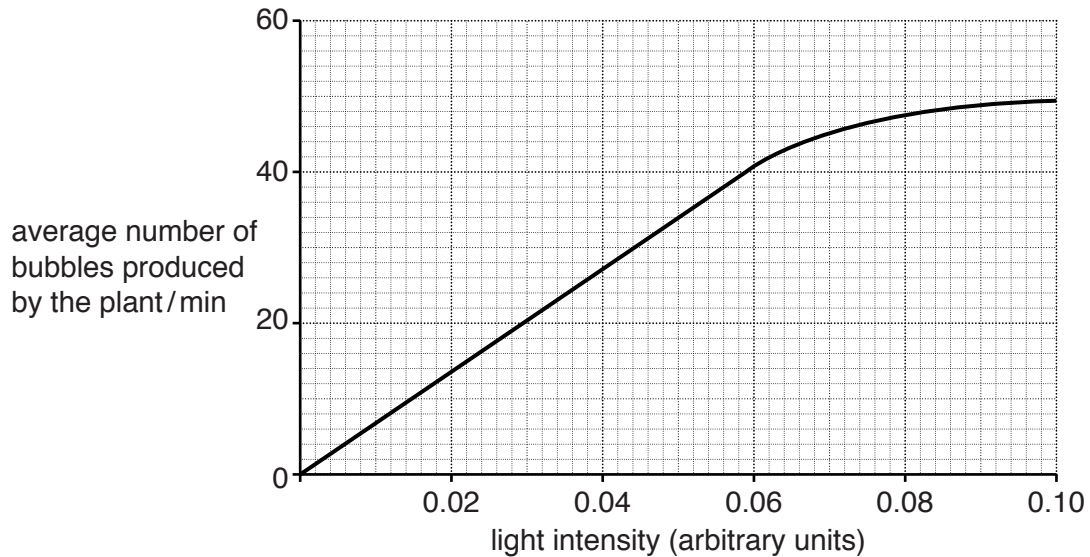

Fig. 3.2

- (a) Use data from the graph in Fig. 3.2 to describe the effect of light intensity on the rate of photosynthesis.

.....

.....

.....

.....[2]

- (b) (i) The piece of *Elodea* is then cut into two pieces of equal size. The experiment is repeated with **one** of these pieces.

On Fig. 3.2 draw a line to suggest how the number of bubbles per minute would change with increasing light intensity when one of these smaller pieces of *Elodea* is used. [1]

- (ii) Explain your reasons for the line you drew in (i).

.....

.....

.....[2]

- (c) *Elodea* forms part of a food chain in a garden pond. The food chain is shown in Fig. 3.3.

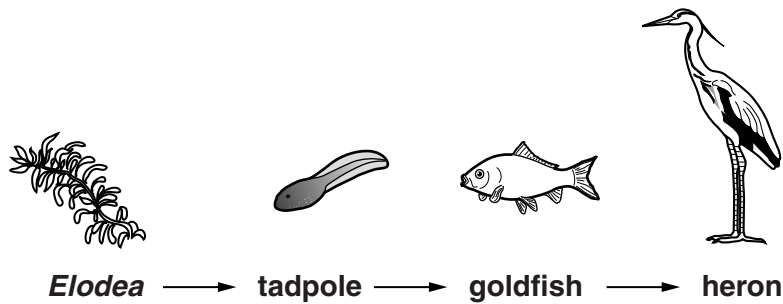

Fig. 3.3

- (i) State **all** the consumers in this food chain.

.....[1]

- (ii) When a goldfish eats a tadpole, most of the chemical energy in the tadpole is lost and does **not** become part of the goldfish's body.

Describe **two** reasons for this energy loss.

1.

.....

2.

.....[2]

(d) Fig. 3.3 on page 7 shows the following food chain.

Elodea → tadpole → goldfish → heron

A second food chain in the pond is shown in Fig. 3.4.

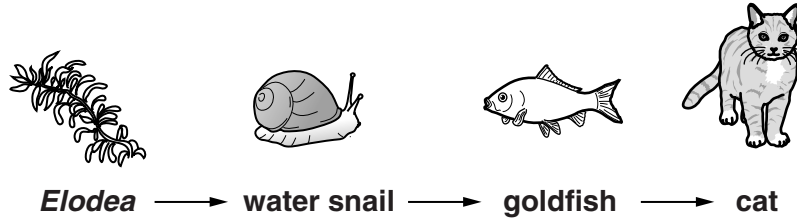

Fig. 3.4

In the space below combine the food chains in Fig. 3.3 and Fig. 3.4 to produce a food web.

[2]

4 Fig. 4.1 shows Group I of the Periodic Table of elements.

3 Li lithium 7
11 Na sodium 23
19 K potassium 39
37 Rb rubidium 85
55 Cs caesium 133
87 Fr francium -

Fig. 4.1

(a) Deduce the number of electrons in each shell of one atom of sodium.

.....[1]

(b) (i) Sodium reacts vigorously with water to form sodium hydroxide solution and hydrogen gas.

Balance the equation below and complete the state symbols. One state symbol has been done for you.

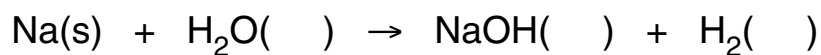

[2]

(ii) Predict what is observed when rubidium reacts with water.

.....

[2]

(iii) State one energy transfer that occurs during the reaction between rubidium and water.

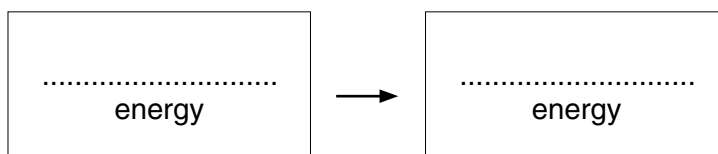

[1]

(c) Explain why elements in Group I are more reactive than elements in Group VIII (noble gases).

.....
.....
.....
.....
.....
.....
.....[2]

(d) Unpolluted air contains nitrogen, oxygen, noble gases, water vapour and carbon dioxide.

(i) Explain how increasing levels of carbon dioxide in the Earth's atmosphere contribute to global warming.

.....
.....
.....
.....[1]

(ii) Suggest **one** negative effect of global warming.

.....
.....[1]

5 A man is climbing a mountain.

(a) State the form of energy the man has gained at the top of the mountain.

.....[1]

(b) The man makes a loud noise as he climbs. The echo from another mountain 990m away reaches him 6 seconds later. This is shown in Fig. 5.1.

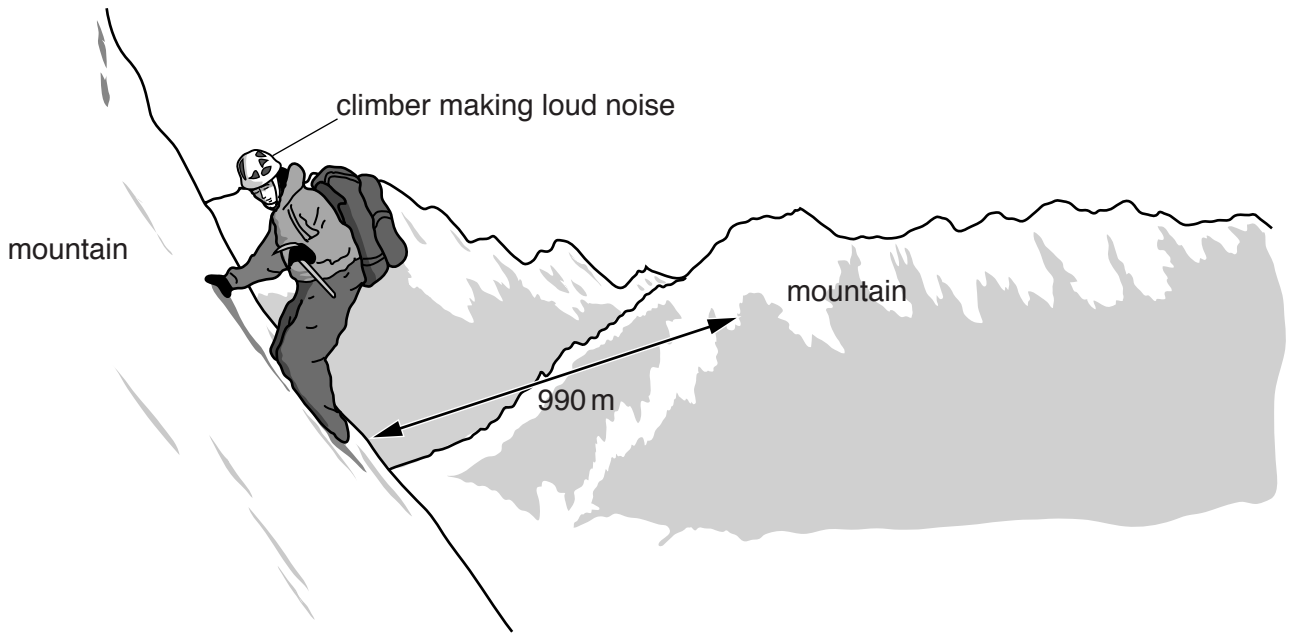

Fig. 5.1 (not to scale)

Use this data to calculate the speed of sound in the air between the two mountains.

State the formula you use and show your working.

formula

working

speed = m/s [2]

(c) A physics website states that sound is a longitudinal wave with a frequency within the human audible frequency range.

(i) Describe one difference between the properties of a longitudinal wave and a transverse wave.

.....
.....
.....
.....[1]

(ii) State the approximate range of human audible frequencies.

lowest frequency Hz
highest frequency Hz [1]

(d) On the mountain, the climber sees some ice melting.

(i) State the meaning of the term *melting point*.

.....
.....
.....[1]

(ii) Fig. 5.2 shows the arrangement of particles in a solid and a liquid.

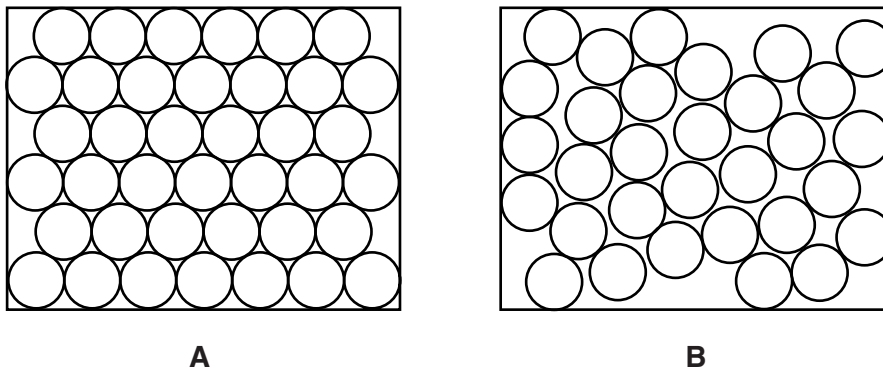

Fig. 5.2

When ice melts it forms liquid water.

Describe how diagram **B** represents the way particles are arranged in water.

.....
.....
.....[2]

(e) On the mountain, the climber is exposed to both infra-red and ultraviolet radiation.

Infra-red and ultraviolet radiation are both electromagnetic waves.

Infra-red waves travel at a speed of 3×10^8 m/s.

State the speed at which ultraviolet waves travel. Explain your answer.

speed = m/s

explanation

.....[1]

6 (a) Fig. 6.1 shows an artery and a vein in longitudinal section.

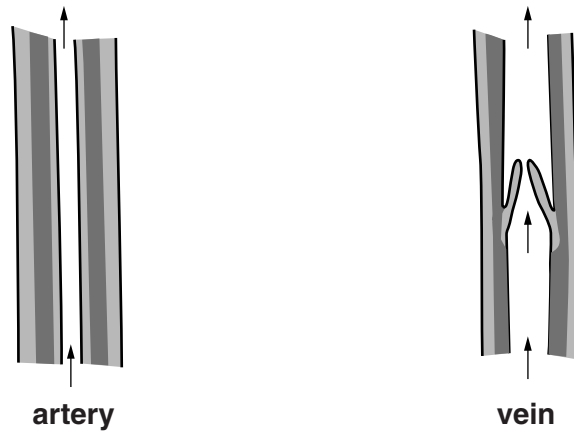

Fig. 6.1

Describe **one** structural adaptation of each blood vessel for its function.

artery

.....

.....

.....

vein

.....

.....

.....

[3]

(b) Complete the following paragraph with the correct terms from the list.

You may use each term once, more than once, or not at all.

- away from blue deoxygenated hepatic vein inside
 oxygenated pulmonary vein red towards vena cava

Veins transport blood the heart. They usually
 contain blood. One vein that contains
 blood is the
 which transports blood the lungs.

[5]

7 Electrolysis breaks down ionic compounds into their elements. Fig. 7.1 shows the electrolysis of molten magnesium chloride, MgCl_2 .

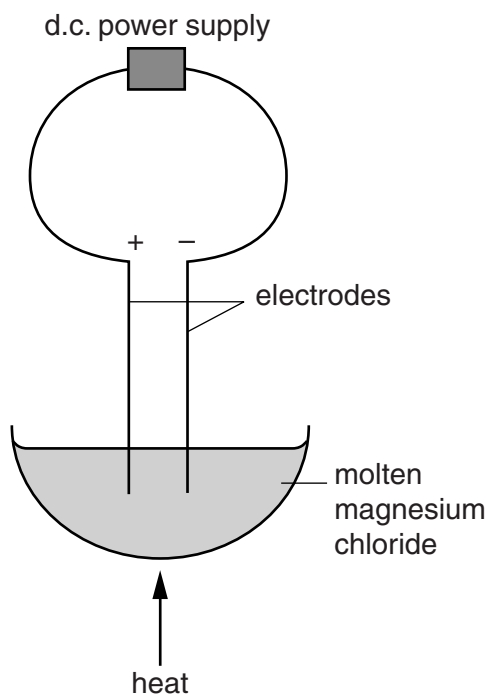

Fig. 7.1

(a) Predict the product that forms at the positive electrode (anode).

..... [1]

(b) Magnesium alloys are often used to make car parts because the alloy is strong.

(i) Draw a diagram in the box to show the arrangement of atoms in a typical alloy.

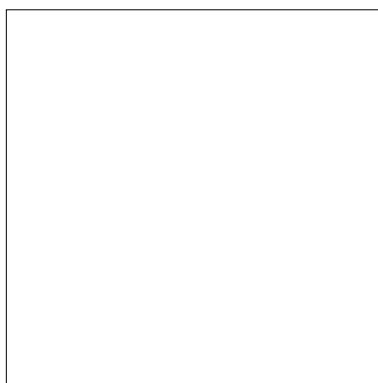

[2]

(ii) Suggest why magnesium alloys are stronger than magnesium metal.

.....

 [1]

- 8 A truck travels at a constant speed for 60 seconds and then slows down. It takes another 40 seconds to come to a stop.

Fig. 8.1 shows the speed/time graph for the 100 second journey.

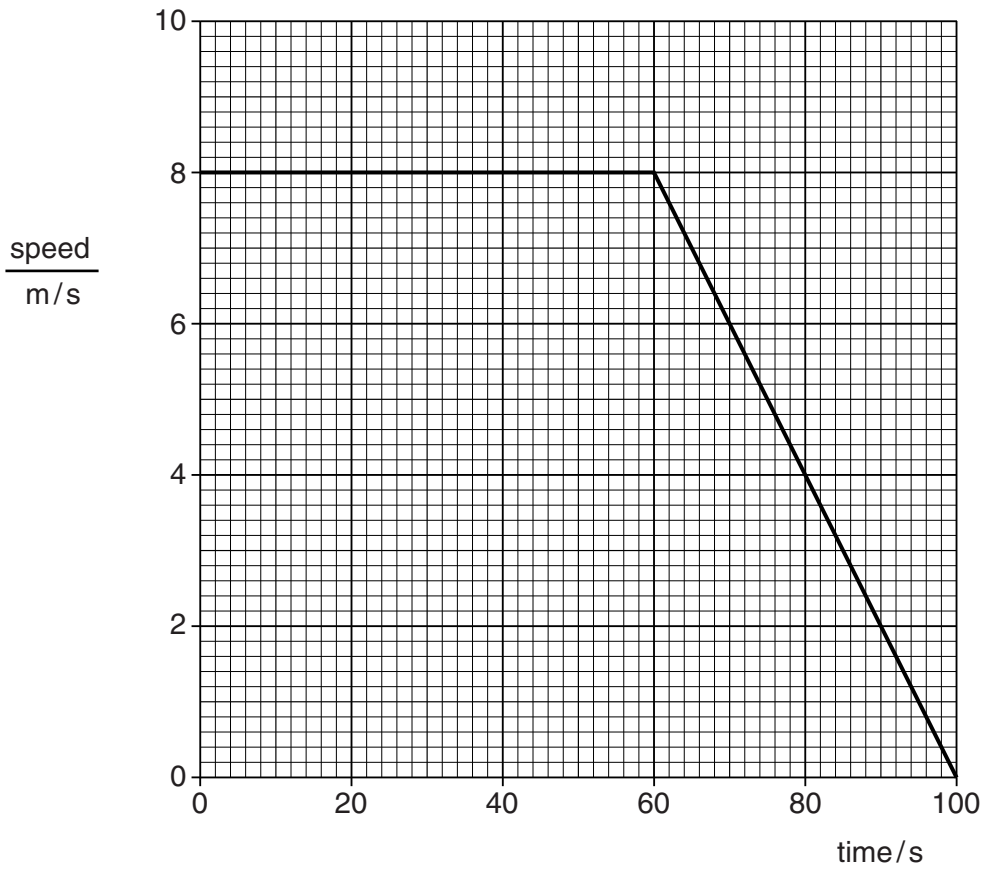

Fig. 8.1

- (a) Calculate the deceleration of the truck between 60s and 100s.

Show your working.

deceleration = m/s² [2]

- (b) Describe how to use the graph to find the total distance travelled by the truck.

.....

 [2]

(c) Fig. 8.2 shows the forces on the truck when it is travelling at constant speed.

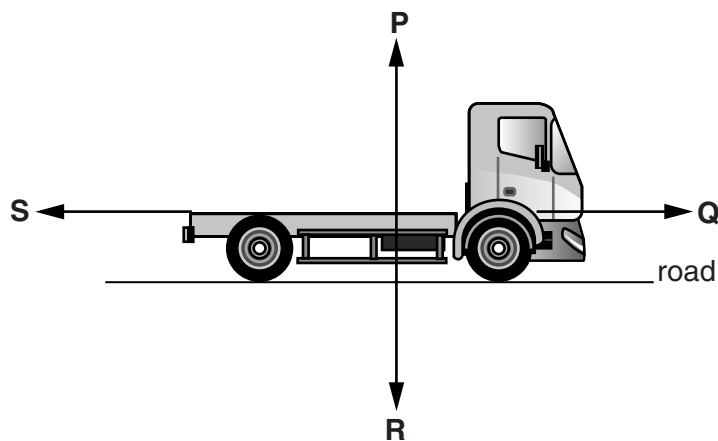

Fig. 8.2

Four forces **P**, **Q**, **R** and **S** are shown.

State which force from **P**, **Q**, **R** and **S** is

1. the weight of the truck,
2. the force exerted by the push of the engine.

[1]

(d) In modern trucks, computers are used to control the engine. Information is passed between the computer and engine along optical fibres.

Light passes through an optical fibre by total internal reflection.

Complete Fig. 8.3 to show how a ray of light travels down an optical fibre by total internal reflection. The first angle of incidence (*i*) has been labelled for you.

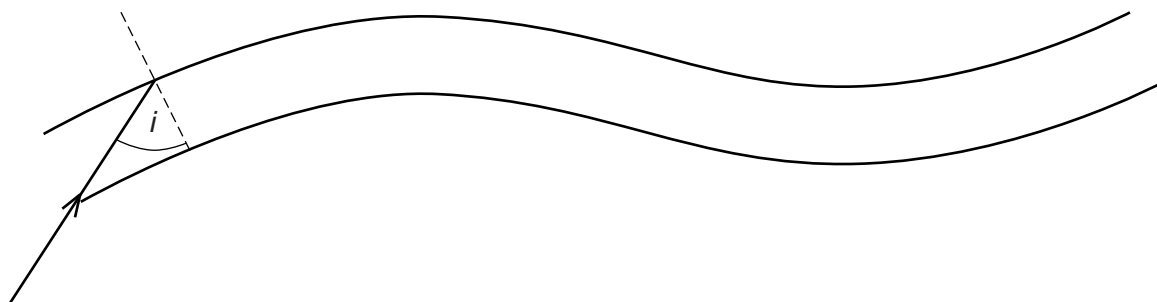

Fig. 8.3

[2]

(e) (i) State one use of optical fibres in medicine.

.....
[1]

(ii) Suggest the advantage of using optical fibres for the use stated in (i).

.....
[1]

9 (a) Complete the balanced symbol equation for aerobic respiration.

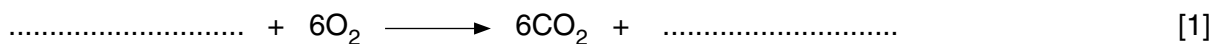

[1]

(b) During aerobic respiration, carbon dioxide is produced which is excreted at the lungs. Fig. 9.1 shows part of the tissue that lines the trachea.

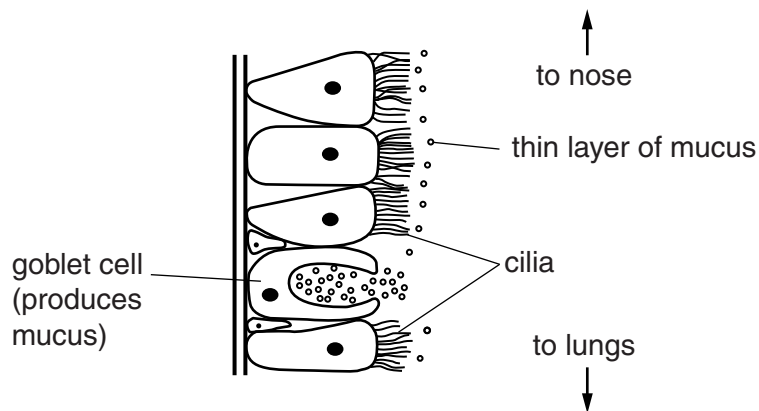

Fig. 9.1

(i) Describe how the lungs are protected by the mucus and cilia shown in Fig. 9.1.

mucus

.....

cilia

.....

[2]

(ii) Describe and explain the harmful effect of tobacco smoke on the cilia.

.....

.....[2]

- (c) Fig. 9.2 shows a fetus in the uterus. The fetus cannot breathe inside the uterus, so oxygen is supplied by a different method.

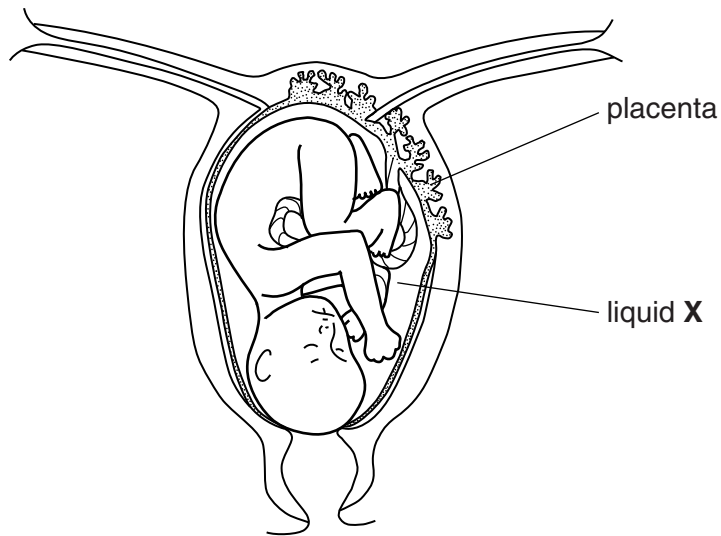

Fig. 9.2

Describe how the placenta supplies the fetus with oxygen.

.....
.....
.....[2]

- (d) (i) One problem that can occur during pregnancy is the loss of the liquid X shown in Fig. 9.2.

Name liquid X.

.....[1]

- (ii) Suggest why the loss of liquid X would be harmful to the growing fetus.

.....
.....[1]

